



**INOX<sup>®</sup>**

security at a higher level

**NIGHT VISION COLOR CAMERA**



- Infrared Night Vision up to 80 meters
- 112 high brightness infrared LED
- Made for total darkness area surveillance
- Anti-Reflect-Blur-Free Technology
- Fully automatic DAY & NIGHT changeover
- Rust proof aluminium housing & bracket

**80 METERS NIGHT VISION**  
MODEL: **XR20 INFRARED**

## IT'S FULLY AUTOMATIC ..... from day to night changeover

Built-in with a light detection sensor, the XR20 is fully automatic when it comes to day to night or night to day surveillance changeover. The camera automatically changes to infrared night vision surveillance when the installation scene illumination is lower than 1 Lux (dark) and changes back to normal colour video mode when the light sensor detects lighting level above 1 Lux.



Day (Color)



Night (Black & White)

## HEATLESS DESIGN...built in blower..

The main issue encounter for most of the on-market long range IR cameras is heat. Infrared LED's inside the camera produces heat. Gathered heat inside the camera causes multiple kinds of issue such as shorter lifespan of the camera and IR LED, lower performance during night vision after a certain period of operation hours and so on...



With the built-in blower inside XR20, such issue will be almost totally avoided. Users are guaranteed to experience the best performance produced by the camera without any issues.

## RUST-FREE WEATHERPROOF housing & bracket.....

It would not rust & it's also weather-proof..... you can install it anywhere you need it. The XR20 outer casing & bracket are made from rust-free aluminum material.

Creating a worry free solution for every outdoor installation....



## BRIGHTER & CLEARER video with CS MOUNT lens technology..



CCD image  
pick up sensor



**XR20**  
with CS mount lens  
(During Night Vision)



CCD image  
pick up sensor



**OTHER**  
with board mount lens  
(During Night Vision)

Why is it brighter than others during IR? XR20 uses CS mount type technology for lens. CS mount lenses allow higher amount of light to be passed through to the CCD sensor and produce a significant part in the resulting video image during night vision.

Please view the above comparison video to see the difference between CS mount technology & board mount type cameras.

ARER

**UP TO 80 METERS** in total darkness.....  
WITH **112** UNITS OF IR LED

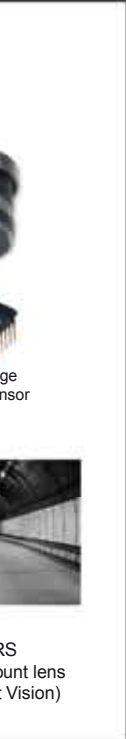
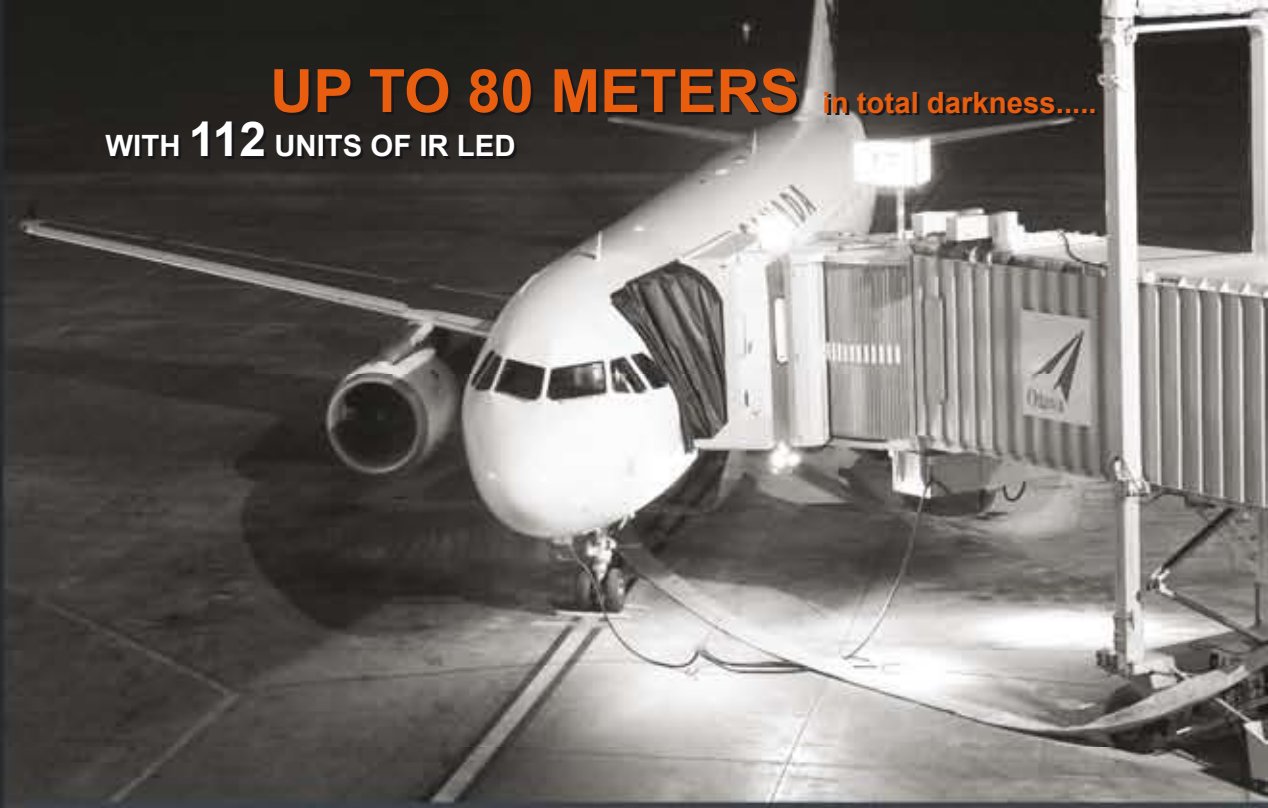

**ANTI-REFLECT-BLUR-FREE** better & clearer video quality ....  
INFRARED SURVEILLANCE WITH DOUBLE-GLASS DESIGN

night vision?  
or its optical  
ounts of light  
d will play a  
brightness

eo between  
chnology IR



**XR-20**  
ANTI-REFLECT-BLUR-FREE  
Double Glass IR Camera  
Non reflection (dust or raindrops)



CONVENTIONAL IR CAMERA  
Video blur cause by raindrops  
gathered in front of IR camera  
glass during raining period



CONVENTIONAL IR CAMERA  
Video blur cause by dust  
gathered in front of IR camera glass  
after 3 weeks of installation



**INOX®**  
www.inox.com.my



**Specifications:**

MODEL	XR20	XR22
IMAGE SENSOR	1/3" SONY Super HAD CCD	
VIDEO RESOLUTION	420 TV Lines	520 TV Lines
MINIMUM ILLUMINATION	0 Lux (IR activated)	
INFRARED DISTANCE	Max. 80 meters	
INFRARED LED	112 units / 850nm	
SYNC SYSTEM	Internal	
WHITE BALANCE	ATW (Auto Tracking White Balance)	
GAIN CONTROL	Automatic (ON)	
SCANNING SYSTEM	2:1 Interface	
S/N RATIO	More than 48db	
ELECTRONIC SHUTTER	PAL - 1/50 ~ 1/1000000 sec. NTSC - 1/60 ~ 1/1000000 sec.	
GAMMA CORRECTION	0.45	
IRIS	A.E.S	
LENS	4mm or 6mm (IR)	
VIDEO OUTPUT	Composite 1.0Vp-p at 75 Ohm	
OPERATION TEMPERATURE	5° C To 60° C	
OPERATIONAL HUMIDITY	Within 85%RH	
POWER SUPPLY INPUT	DC 12 Volts	
OPERATING CURRENT	600 mA + - 10%	
DIMENSION	130mm (L) x 110mm (W) x 110mm (H) (without sunshade)	
WEIGHT	Approx. 1 kgs / without box & bracket	

**Dimension:**

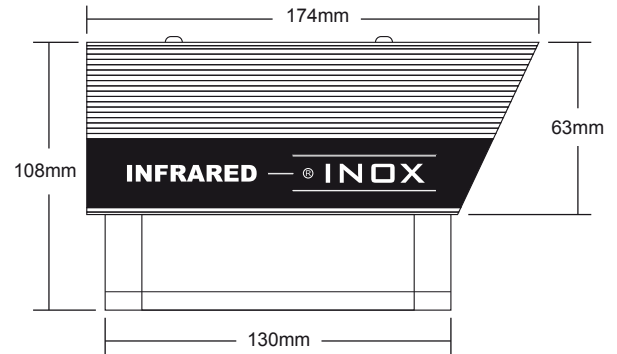
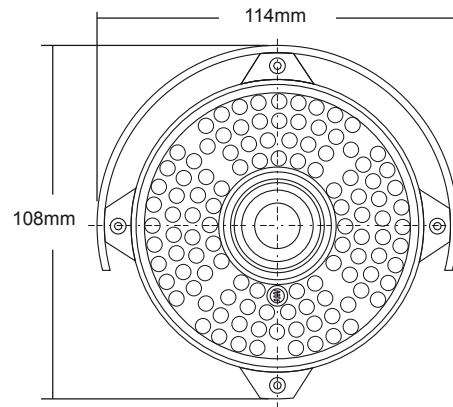

**80 METERS NIGHT VISION**  
MODEL: **XR20 INFRARED**

**INOX SECURITY PTY. LTD.**

- Canada (Incorporation No. BC 0722077)

**INOX MANUFACTURING (M) SDN. BHD.**

- Malaysia (Company No. 671850-H)

Specifications, description and design are subject to changewithout prior notice. The brands and products names are properties of their respective owners